

(12) UK Patent Application (19) GB (11) 2 117 813 A

- (21) Application No 8308941
- (22) Date of filing 31 Mar 1983
- (30) Priority data
- (31) 8210167
- (32) 6 Apr 1982
- (33) United Kingdom (GB)
- (43) Application published 19 Oct 1983
- (51) INT CL³
E04B 2/82
- (52) Domestic classification
E1D 103 358 421 523
F155 LES2
U1S 1742 1966 E1D
- (56) Documents cited
GBA 2099038
GBA 2063952
GBA 2016574
GB 1555087
GB 1307026
GB 0436275
- (58) Field of search
E1D
- (71) Applicant
Leonid Ostrovsky,
62 Blackthorne Bay,
Winnipeg, Manitoba,
Canada, R2P 1S9
- (72) Inventor
Leonid Ostrovsky
- (74) Agent and/or Address for
Service
Withers and Rogers,
4 Dyer's Buildings,
Holborn, London
EC1N 2JT

(54) Pivotal assembly of insulated wall panels

(57) The joint assembly comprises a pair of strips 13, 12 secured to the edges of respective panels by folding the outer skins 10 and by a dovetail joint 20 with the foam insulation material 11. The connecting strips provide a curved tongue 27 and groove 21. The groove strip has a pivotal body 23 of part-cylindrical

shape so that one strip can be pivoted relative to the other for tongue 27 to enter groove 21. Pivotal body 23 lies to one side of tongue 27 and intermediate the height thereof so that in the desired orientation, the curved surfaces of tongue 27 and groove 21 prevent withdrawal of tongue 27 by linear movement. A locking strip 33 can be inserted into a groove; it includes spaced clips 34.

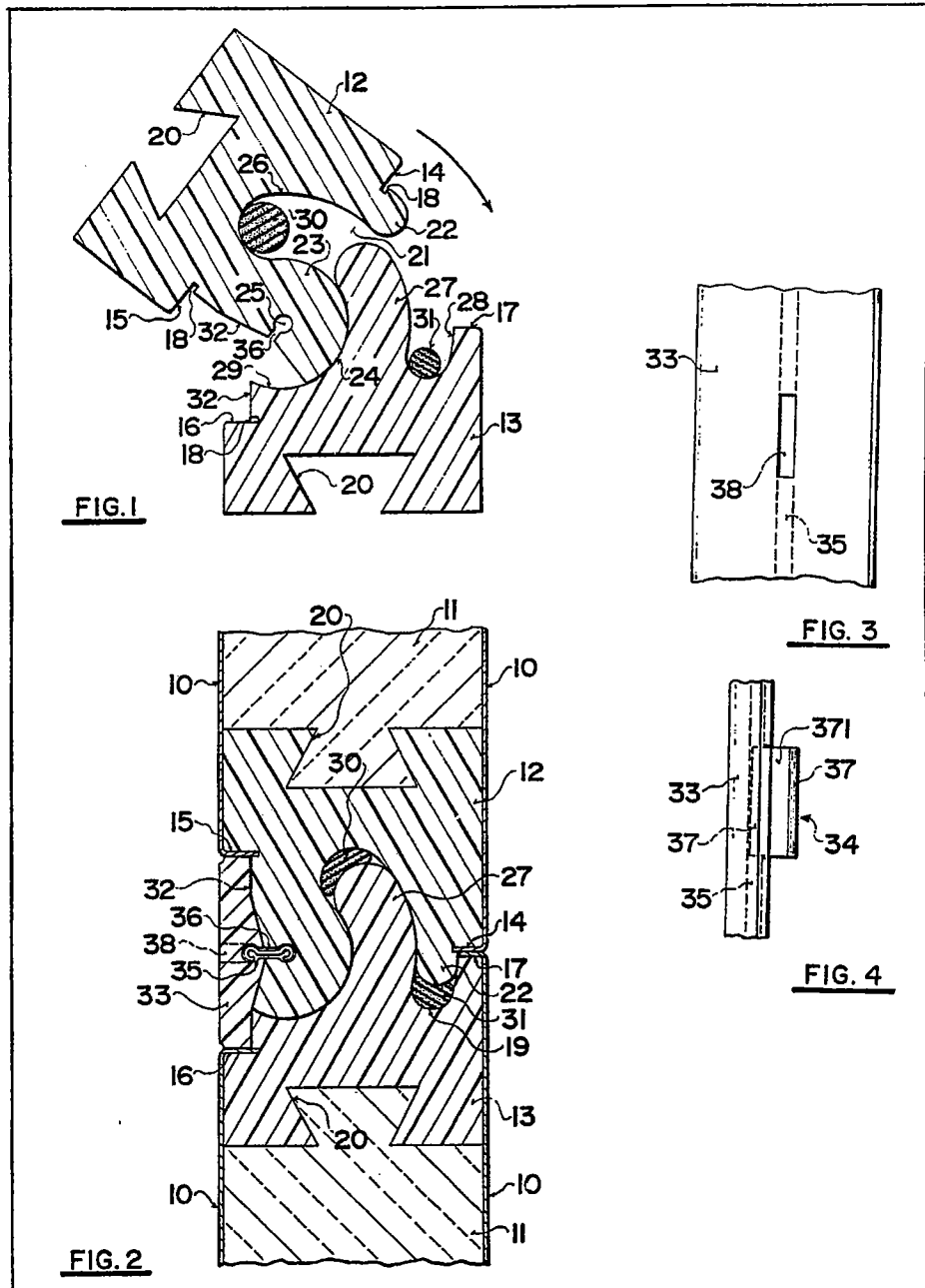

GB 2 117 813 A

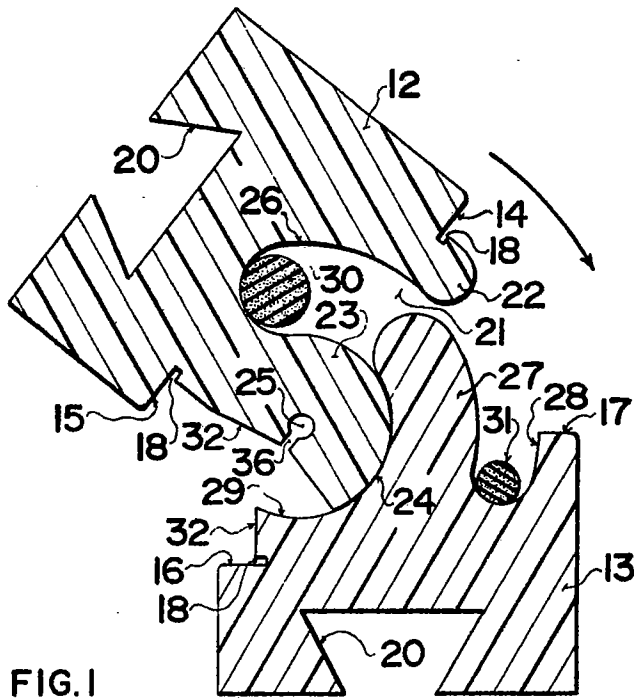

FIG. 1

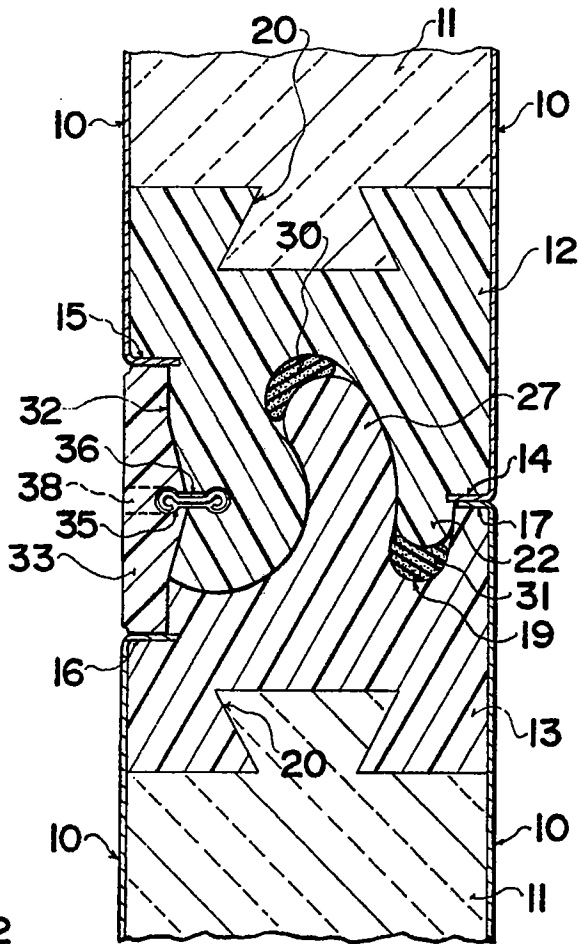

FIG. 2

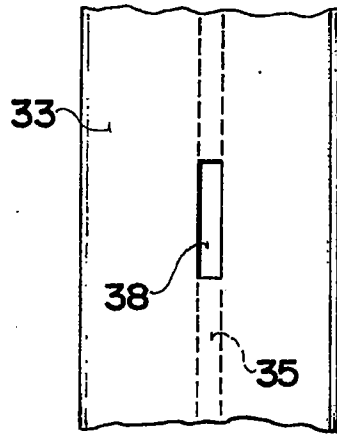

FIG. 3

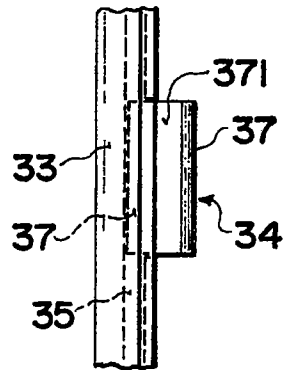

FIG. 4

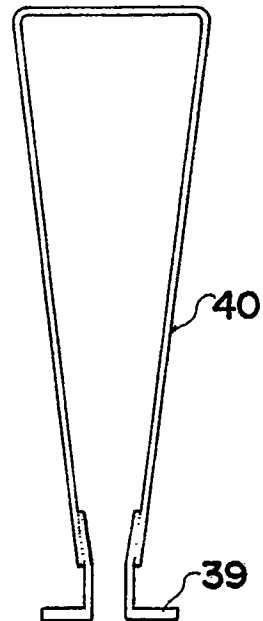

FIG. 5

SPECIFICATION

Connecting wall panels

This invention relates to assemblies for providing abutting connection between panels.

5 Such a connection is generally formed between abutting edges of the panels with the panels lying generally in the same plane but it will be appreciated that right angle connection are also required of panels either at the edge of the panels or sometimes with an edge of one panel abutting an intermediate portion of another panel. In other cases the abutment may lie at angles other than 90° or 180° depending upon requirements.

10 The invention is particularly, although not exclusively, concerned with the abutting edges of insulation panels which comprise a pair of spaced sheet metal layers or skins confining an intermediate layer of a foam insulation material generally formed by injection into the space between the skins. Such panels are well known and are conventionally used for many insulation uses and particularly for forming the walls of a cold storage area.

25 Conventionally such panels have been connected at abutting edges by a tongue and groove connection of a simple nature comprising a rectangular tongue extending directly outwardly from one edge which co-operates with a similar shaped groove in the abutting edge of the next adjacent panel. Tongue and groove connections of this type satisfactorily prevent transverse movement of one panel relative to the other, that is movement transverse to the joint. However they require forces compressing the joint in order to prevent movement of one panel relative to the other at right angles to the joint. Thus the type of structure which can be manufactured from the panels is limited by this requirement in order to maintain a structure which is sound and resistant to collapse.

40 It is one object of the invention to provide an assembly for connecting two panels in abutting relationship of the tongue and groove type where the panels are prevented from separating in a direction at right angles to the joint without the application of compression forces to the joint.

45 According to a first aspect of the invention therefore there is provided a pair of panels having co-operating abutment portions for connection of the edge of a first panel to the second panel in abutting relationship, one of said panels having an elongated tongue directly connected to the panel and lying along the abutment portion thereof and the other panel having an elongated groove directly connected thereto and lying along the abutment portion thereof for co-operation of the sides of the groove with the sides of the tongue such that when in co-operation the tongue lies within the groove to prevent transverse movement of the edge of said first panel relative to the second panel, the co-operating sides of the tongue and of the groove being curved about an axis lying parallel to the tongue, to one side thereof and intermediate the height thereof whereby the

65 tongue can be inserted into the groove by a pivotal movement about the axis to a desired orientation and in the desired orientation the co-operating sides of the tongue and groove prevent the tongue from being withdrawn from the groove by linear movement transverse to the axis.

70 According to a second aspect of the invention there is provided a pair of strips for connection of the edge of one panel to the next adjacent panel in abutting relationship, each strip having means for directly connecting the strip to the respective panel, one strip having an elongated tongue directly connected thereto and lying therealong and the other strip having an elongated groove directly connected thereto and lying therealong for co-operation of the sides of the groove with the sides of the tongue such that when in co-operation the tongue lies within the groove to prevent transverse movement of the edge of said first panel relative to the second panel, the co-operating sides of the tongue and of the groove being curved at an axis line parallel to the tongue, to one side thereof and intermediate the height thereof whereby the tongue can be inserted into the groove by a pivotal movement about the axis to a desired orientation and in the desired orientation the co-operating sides of the tongue and groove prevent the tongue from being withdrawn from the groove by linear movement transverse to the axis.

90 It is one advantage of the invention therefore that the panels can be connected merely by applying the tongue to the groove and then pivoting the tongue into the groove up to the desired orientation. As explained previously the desired orientation can vary according to circumstances with the most common example comprising the edge to edge abutting relationship whereby the panels are formed into a wall.

105 It is a further advantage of the invention that the pivotal movement can be arrested at the desired orientation by co-operating surfaces provided on the edge strips with a locking strip being applied subsequent to the pivotal movement to lock the panels against pivotal movement back from the desired orientation.

110 It is a particular advantage of the invention that it can be readily used with panels of the type comprising metal or other material sheets confining a central layer of insulation material such that each strip provides surfaces at right angles to the outer sheets to receive turned down portions of the outer sheets and a dovetail joint for connecting to the insulation material following its injection into the space between the strip and the outer sheets.

120 It is a further advantage of the invention that the strips forming the connections are formed from simple extrusions which can simply be cut to length and applied to the chosen size of panel.

125 It is a yet further advantage of the invention that by the simple application of resilient sealing beads to the groove and also to an additional groove, the strips can provide effective sealing of the spaces between the insulated panels.

It is a still further advantage of the invention that the locking strip preventing pivotal movement back from the desired orientation can be readily removed so that the panels can be relatively pivoted back from the desired orientation for disassembly. In this way a joint can be readily formed and disassembled which provides complete locking of the panels in the desired orientation with movement in any of the directions prevented without the use of adhesive or other material which would interfere with the disassembly.

With the foregoing in view, and other advantages as will become apparent to those skilled in the art to which this invention relates as this specification proceeds, the invention is herein described by reference to the accompanying drawings forming a part hereof, which includes a description of the best mode known to the applicant and of the preferred typical embodiment of the principles of the present invention, in which:

Figure 1 is a cross-sectional view through two co-operating connecting strips for attachment to the edges of respective panels, showing the strips in the first assembly position prior to pivotal movement to the desired orientation of the panels.

Figure 2 is a similar cross-sectional view of the strips of Figure 1 attached to panels and showing the strips in the desired orientation with the locking strip in situ.

Figure 3 is a partial front elevational view of the locking strip of Figure 2 prior to assembly.

Figure 4 is a side elevational view of the locking strip of Figure 3.

Figure 5 is a plan view of a tool for removing the locking strip from Figure 2 for disassembly of the joint.

In the drawings like characters of reference indicate corresponding parts on the different figures.

As shown in Figure 2, one embodiment of the joint assembly is shown in conjunction with insulation panels each comprising outer sheet metal skins 10 and an intervening layer of insulation material, preferably of the foam type, indicated at 11. One connection strip of the female or groove type is indicated at 12 and the other of the tongue or male type is indicated at 13. Each of the connector strips 12, 13 comprises planar parallel outer surfaces for co-operation with the outer skins 10, each of which surfaces terminates in an inwardly turned surface at right angles to the outer skin, these surfaces being generally indicated at 14 through 17. It will be noted that each of the surfaces 14 through 16 terminates in a slot extending into the body of the connector strip so that the metallic outer sheet or skin 10 can be folded to lie in abutment with the respective surface 14 through 16 with the end of the skin extending into the slot formed in the body of the strip and indicated generally at 18. The surface 17 lies adjacent a groove 19 described in more detail hereinafter and hence cannot include the slot 18.

In this way the strip 12, 13 is secured along the

edge of the outer skins 10 of the panel to close the panel. The strips 12, 13 can be cut from an extruded section so that they can be readily cut to length dependent upon the size of the panel and hence the size of the parallel skins 10. The panel can be formed from the skins 10 with each of the four edges being defined by a male or female type strip 12, 13 or alternatively only one or two of the edges can be formed by the strips 12, 13 with the other edges being formed merely by simple closing strips without the complicated inter-connecting surfaces described hereinafter.

Subsequent to assembly of the panel including the skins 10 and the edges 12, 13 the insulating foam is injected into the interior so as to fill the interior and form an insulating layer substantially preventing the conduction of heat from one outside skin to the other skin. Each of the strips 12, 13 includes a dovetail groove 20, that is a groove with the side walls inclined inwardly so that when the foam material is injected into the space within the panel it enters the dovetail groove 20 to form a dovetail joint between the strip and the foam material. In this way a rigid insulation panel is formed with the strips 12, 13 firmly attached thereto and effectively integral therewith.

The female or grooved strip 12 includes a groove 21 which is narrow in comparison with the width of the panel, and is substantially longer than its width. On one side of the groove 21 is provided a tongue 22 which is a small or subsidiary tongue relative to the size of the groove 21 and extends outwardly from the transverse surface 14 with the groove 18 formed into the body of the tongue 22.

On the other side of the groove 21 is formed a pivot body 23 extending outwardly toward the male strip 13 and providing a part cylindrical surface 24 curved about an axis 25 within the pivot body 23. The part cylindrical surface 24 forms one side of the groove 21 with the other side of the groove 21 indicated at 26 being similarly curved about the axis 25 so that the groove as a whole forms a curved channel lying on the arc of a circle with its center lying on the axis 25.

The male or tongued strip 13 includes a tongue 27 having on one side a groove 28 for co-operating with the tongue 22 and a part cylindrical recess 29 for co-operating with the pivot body 23. In addition the surface 17 of the strip 13 co-operates with the surface 14 of the strip 12.

Thus the abutting surfaces of the strips 12 and 13 are of the same co-operating shape except that the grooves 21, 28 are deeper than the corresponding tongue 27, 22. In the base of each of the grooves is fixed suitably by adhesive a resilient bead 30, 31 respectively.

As shown in Figure 1, the panels are connected together initially by pivoting one panel relative to the other about the axis 25 so that the pivot body 23 can be inserted into the corresponding recess 29 with the tongue 27 outside the groove 21. By pivotal movement of the upper panel controlled by rotation of the pivotal body 23 in the recess 29

the groove 21 can be moved down onto the tongue 27 until the surface 14 engages the surface 17. Since the tongue 27 and groove 21 are similarly curved about the axis 25 the entry of the tongue 27 into the groove 21 follows the

5 pivotal movement. When the surface 14 engages the surface 17, the tongue 22 is inserted into the groove 28 to assist the main tongue 27 in locating the strip 13 relative to the strip 12.

10 The beads 30 and 31 are of a sufficient size so that in the fully pivoted position shown in Figure 2 comprising the desired orientation of the panels the beads 30, 31 are compressed by the

15 respective tongue 27, 22 to assist in preventing pivotal movement beyond the desired orientation and to provide a seal to prevent the passage of air through the space between the panels defined by the strips 12 and 13.

20 A groove defined by the surfaces 15, 16 and a surface extending therebetween indicated at 32 is formed partly in the strip 12 and partly in the strip 13. The surface 32 is not planar but extends downwardly adjacent its center toward the axis 25. The groove is symmetrical relative to the axis

25 25 so that the surfaces 16, 15 are equidistant from the axis.

A locking strip 33 of equal length to the strips 12, 13 is inserted into the groove when the panels are in the desired orientation. The locking strip is shown in more detail in Figures 3 and 4 and includes a plurality of spaced clips 34. To receive the clips 34, the locking strip 33 includes a slot 35 along its full length centrally thereof and directed toward a co-operating slot 36 provided along the pivot body 23. The slots 35 and 36 each have an enlargement at the base for co-operating with a bead section 37 of the clips 34. Specifically the clips are formed of bent metal to form a web section 371 joining the two bead sections 37 which comprise a rolled part of the metal strip fully or partly into a cylinder. Thus with the clips 34 glued into spaced location in the locking strip 33, the exposed portion of the clips can be inserted into the groove 36 thus locking the strip 33 into position in the groove 32.

40 Intermediate the clips 34, the strip 33 has a plurality of slots 38 communicating from the channel 35 to the front exposed face of the strip. The slots 38 are of sufficient length to receive the jaws 39 of a tool 40 with the tool closed together so that when the jaws 39 are opened into the channel 35 the locking strip 33 can be pulled out of the groove 32. In this way the strip 33 can be removed and the panels relatively pivoted for disassembly of the joint formed by the strips 12, 13.

50 While the desired orientation shown in the embodiment described above provides a co-planar arrangement of the panels, it will be appreciated that strips using the same principles of connection could be provided on the edge of similar panels to provide other angles of desired orientation, for example a 90° orientation. Such joints could be used between the walls and floor or between the walls and ceiling of a cold storage area thus

forming a rigid structure with the joints resistant to separation without necessity for compressive forces at the joint.

70 In a further alternative arrangement, it will be appreciated that the technique of jointing can be used between the edge of one panel and a side face of another panel with the strips secured accordingly.

75 While the strips of the embodiment described above are formed effectively, integrally with the panel, it is possible that the strips comprise separate integers which can be secured to separately manufactured panels by any suitable technique. The panels concerned could be of a solid structure as opposed to the laminate structure of the above embodiment.

80 Since various modifications can be made in my invention as hereinabove described, and many apparently widely different embodiments of same made within the spirit and scope of the claims without departing from such spirit and scope, it is intended that all matter contained in the accompanying specification shall be interpreted as illustrative only and not in a limiting sense.

90 CLAIMS

1. A pair of panels having co-operating abutment strips for connection of the edge of a first panel to the second panel in abutting relationship, one of said panels having an elongated tongue directly connected to the panel and lying along the abutment portion thereof and the other panel having an elongated groove directly connected thereto and lying along the abutment portion thereof for co-operation of the sides of the groove with the sides of the tongue such that when in co-operation the tongue lies within the groove to prevent transverse movement of the edge of said first panel relative to the second panel, the co-operating sides of the tongue and of the groove being curved about an axis lying parallel to the tongue, to one side thereof and intermediate the height thereof whereby the tongue can be inserted into the groove by a pivotal movement about the axis to a desired orientation and in the desired orientation the co-operating sides of the tongue and groove prevent the tongue from being withdrawn from the groove by linear movement transverse to the axis.

2. A pair of strips for connection of the edge of one panel to the next adjacent panel in abutting relationship, each strip having means for directly connecting the strip to the respective panel, one strip having an elongated tongue directly connected thereto and lying therealong and the other strip having an elongated groove directly connected thereto and lying therealong for co-operation of the sides of the groove with the sides of the tongue such that when in co-operation the tongue lies within the groove to prevent transverse movement of the edge of said first panel relative to the second panel, the co-operating sides of the tongue and of the groove being curved at an axis line parallel to the tongue, to one side thereof and intermediate the height

thereof whereby the tongue can be inserted into the groove by a pivotal movement about the axis to a desired orientation and in the desired orientation the co-operating sides of the tongue and groove prevent the tongue from being withdrawn from the groove by linear movement transverse to the axis.

3. An assembly according to Claim 1 or 2 wherein the strips include co-operating surfaces for preventing pivotal movement beyond said desired orientation.

4. An assembly according to Claim 1, 2 or 3 including means for locking the strips against pivotal movement back from said desired orientation.

5. An assembly according to Claim 4 wherein the locking means comprises a locking strip and a co-operating groove defined between said strips whereby with said locking strip inserted in said groove edges of the groove act to compress the locking strip on pivotal movement back from said desired orientation.

6. An assembly according to Claim 5 wherein said groove is provided by co-operating recesses defined in said strips.

7. An assembly according to Claim 5 or 6 wherein said groove is substantially symmetrical about a plane passing through the axis.

8. An assembly according to Claim 5, 6 or 7 including means for clipping the locking strip into the groove.

9. An assembly according to Claim 8 wherein said clipping means comprises a web and bead portion extending outwardly from the locking strip and slidable into a co-operating shaped channel formed in one of said strips.

10. An assembly according to Claim 9 wherein the bead lies along the axis.

11. An assembly according to Claim 8, 9 or 10

40 including a plurality of slots provided in said locking strip for receiving a tool whereby the locking strip can be removed from the groove.

12. An assembly according to any preceding claim wherein the axis lies closer to one side of the strip than the other side and wherein co-operating transverse edges are defined on the strips adjacent the other side to prevent pivotal movement beyond said desired orientation.

13. An assembly according to any preceding claim wherein, in the desired orientation, the tongue extends substantially to the bottom of the groove and wherein there is provided a resilient sealing bead extending along the bottom of the groove which is compressed by the tongue in said desired orientation.

14. An assembly according to any preceding claim including a groove on the strip adjacent the tongue for receiving a co-operating tongue on the strip adjacent to the groove.

15. An assembly according to Claim 14 wherein, in the desired orientation, the additional tongue extends substantially to the bottom of the additional groove and wherein there is provided a resilient bead along the bottom of the groove which is compressed by the additional tongue in the desired orientation.

16. A pair of panels having co-operable edges whereby an edge of a first panel can be arranged in abutting relation with an edge of a second panel, the said edges having respectively a tongue and a groove, the co-operating sides of the tongue and groove being substantially of part cylindrical shape so that the first panel can be pivoted relative to the second to insert the tongue into the groove.

17. An assembly of panels constructed and arranged substantially as described herein with reference to the accompanying drawings.